



Subscribe to  
Caron Connections, our free e-newsletter.

Enter your e-mail address

Subscribe

*The Yarn. The Web. The Experience.*

Home

Yarns

Pattern Boutique

Designer Studio

Guide to Style

Caron Blog

Where to Buy

## Apogee Wrap

designed by  
Kristin Omdahl



Technique used: Knit



INTERMEDIATE  
YARN

[NaturallyCaron.com Spa](http://NaturallyCaron.com Spa)

(75% Microdenier Acrylic/25% Bamboo):

#0008 Misty Taupe (MC), 14 oz/396gr

One circular needle size US 5 (3.75mm), 24" long

One circular needle size US 8 (5mm), 32" long or  
size to obtain gauge

One set of 4 (5) double pointed needles (dpn) size  
US 8 (5mm)

Stitch markers

Tapestry needle (tn)

Yarn needle



Click for audio fashion show



click to enlarge

[schematic](#)

[Printer Friendly instructions](#)

**Updated 11/27/11**

**SIZES:** One size

**KNITTED MEASUREMENTS:**

Length: 25"/63.5 cm

**GAUGE**

In blocked lace stitch, using size US 8 (5mm) needles, 14 sts and 21 rows = 4"/10 cm

**STITCHES USED**

Garner stitch (Garner st)

Modified Feather & Fan stitch pattern (see chart and line by line instructions)

**Notes:**

Body is worked from the neck down, with 3 pattern repeats between each set of 5-stitch garter stitch sections (See schematic).

First stitch of every row is slipped knitwise to form a firm selvedge edge.

### WRAP

With smaller needles, cast on 71 sts

Knit 4 rows

Change to larger needles

**Row 1 (WS):** Sl 1, k4, \*place marker (pm), p6, k5; repeat from across--71 sts.

**Row 2 (RS):** Sl 1, k4, \*slip marker (sm), k6, p5 repeat from \* across.

**Row 3:** Sl 1, k4, \*sm, p6, k5; repeat from \* across.

**Row 4:** Repeat Row 2

**Row 5:** Repeat Row 3

**Row 6:** Sl 1, k4, \*sm, (k1, yo), 6 times, k5; repeat from \* across--107 sts.

**Row 7 (and all odd numbered rows):** Sl 1, k4, \*sm, purl to 5 sts before next st marker, k5' repeat from \* to end.

**Row 8:** Sl 1, k4, knit across slipping markers as you go.

**Row 10:** Sl 1, k4, \*sm, (k1, yo, k3, yo) 3 times, k5; repeat from \* across--143 sts.

**Row 12:** Sl1, k4, knit across, slipping markers as you go.

**Row 14:** Sl1, k4, \*sm, (k1, yo, ssk, yo, k1, yo, k2tog, yo)x3, k5. Repeat from \* across--179 sts.

**Row 16:** Sl 1, k4, knit across, slipping markers as you go.

**Row 18:** Sl 1, k4, \*sm, (k1, yo, k7, yo) 3 times, k5; repeat from \* across--215 sts.

**Row 20:** Sl 1, k4, \*sm, [k1, ssk, (yo, k1) 3 times, k2tog 2 times] 3 times, k5; repeat from \* across.

**Row 22:** Sl 1, k4, \*sm, (k1, yo, k9, yo) 3 times, k5; repeat from \* across--251 sts.

**Row 24:** Sl 1, k4, \*sm, [ssk 2 times, (k1, yo) 4 times, k2tog 2 times]3 times, k5; repeat from \* across.

**Row 26:** Sl 1, k4, \*(k1, yo, k11, yo) 3 times, k5; repeat from \* across--287 sts.

**Row 28:** Sl 1, k4, knit across.

**Row 30:** Sl 1, k4, \*[k1, yo, ssk 2 times, (k1, yo) 4 times, k2tog 2 times, k1, yo] 3 times, k5; repeat from \* across--323 sts.

**Row 32:** Repeat row 28.

**Row 34:** Sl k4, \*(k1, yo, k15, yo) 3 times, k5; repeat from \* across—359 sts.

**Row 36:** Sl1, k4, \*[ssk 3 times, (k1, yo) 6 times, k2tog 3 times] 3 times, k5; repeat from \* across.

**Row 38:** Repeat row 28.

**Row 40:** Repeat row 28.

Repeat rows 35 – 40 until piece is 24" from cast on edge (estimated, blocked measurement)

Knit 8 rows. Bind off loosely.

### I-cord Belt:

With dpns, CO 5 sts

**Row 1:** Slip sts to other side of needle. K5

Repeat Row 1 until I-cord is 40" long.

Bind off.

### FINISHING

Block pieces to measurements.

Using yarn needle, weave in ends.

Realizing that the wrap has 6 wedge sections, you will be weaving the belt to cinch the 1st, 3rd, 4th, and 6th sections for the body, skipping the 2nd and 5th sections for 'sleeves'. Weave belt through eyelets in lace, inserting the belt at the end of the first section, skip the 2nd section, weave the belt through the beginning of the next wedge in a lace eyelet, skip to the end of the 4th section and weave the belt through a lace eyelet, skip the 5th wedge, and pull the belt through a lace eyelet at the beginning of the 6th wedge. When you cinch the belt, the body will hug your waist, and the 'sleeves' will flow around your arms.

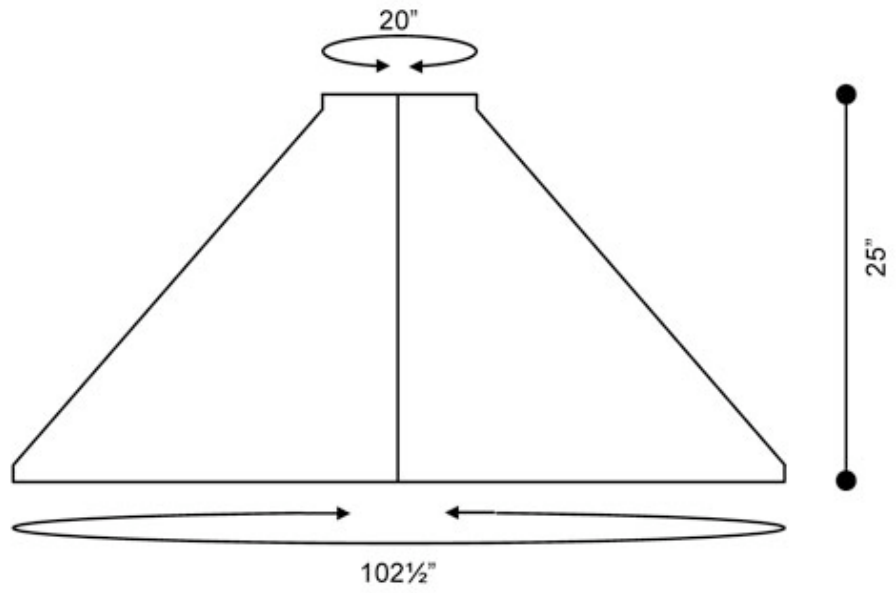

**CARON**  
©2011 Caron International